

DETAILED PARTS AND ASSEMBLY PROCEDURE

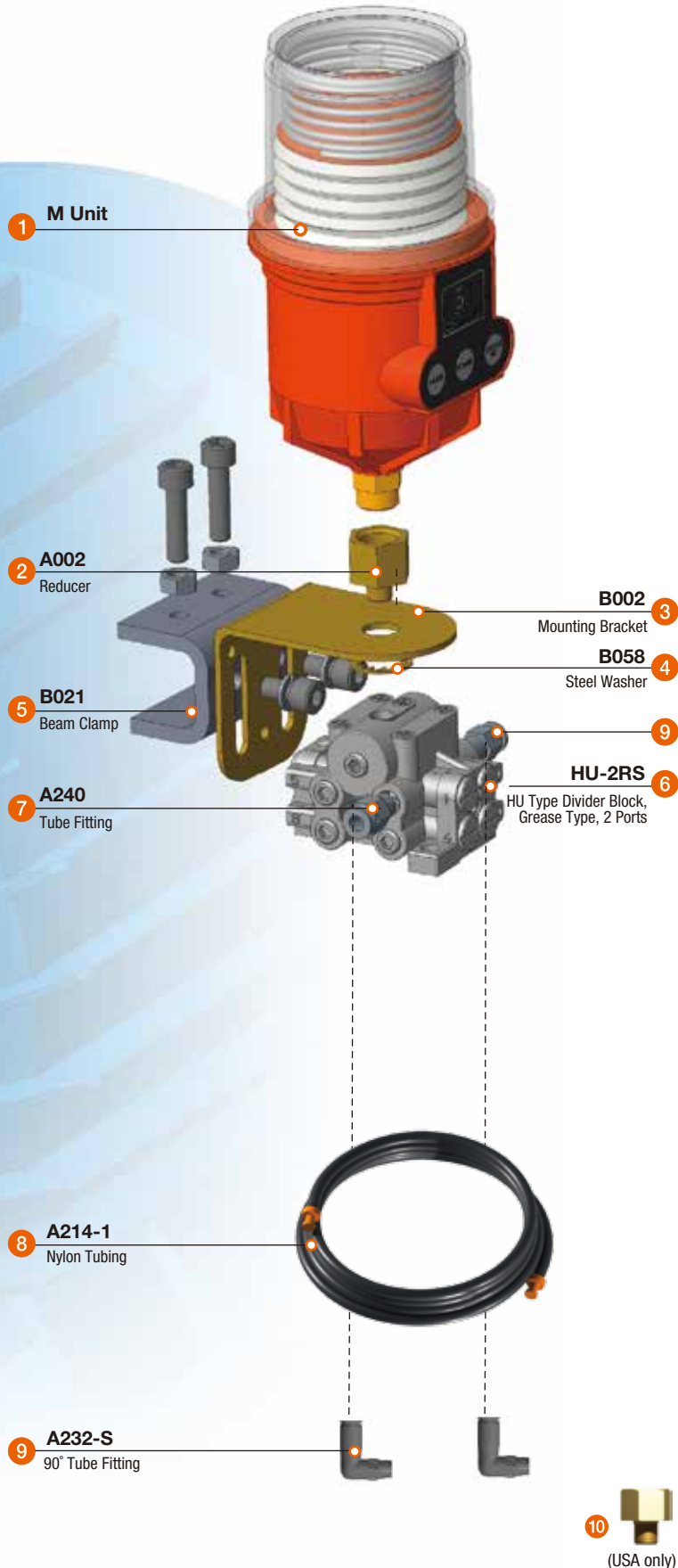

LIST	Part No.	DESCRIPTION	Q'TY
1	M Unit	Pulsarlube M Series	N/A
2	A002	Reducer, 3/8" F X 1/8" M Adaptor (Brass)	1
3	B002	Mounting Bracket, "L" Shape	1
4	B058	Steel Washer	1
5	B021	Beam Clamp 30mm (Stainless)	1
6	HU-2RS	HU Type Divider Block, Grease Type, 2 Ports	1
7	A240	Tube Fitting, Push-In Type, PC6-PT1/8" M	2
8	A214-1	Distribution Tubing, O.D. 1/4" (6mm) Nylon Tubing, 10ft (3m) Pre-filled with (Grease Type)	1
9	A232-S	90° Tube Fitting, Push-In Type, PC6-PT1/8" M Swivel Type (Nickel Plated)	2
10	A243	Metric to inch thread converter for bearing zerck (USA only)	1

Assembly Procedure

1. Assemble Mounting Bracket (3) and Beam Clamp (5) together.
2. Install HU-2RS (6) on the Mounting Bracket (3) firmly using provided reducer (2) and washer (4).
3. Install tube fittings (7) into divider block.
4. Place Beam Clamp (5) on the motor and tighten the bolts until the clamp is affixed.
5. Install 90° swivel fittings (9) into lube point.
6. Connect nylon tubing (8) to tube fitting and 90° swivel fitting.
7. Install lubricator and follow lubricator operation instructions on user manual.

Comments

1. Apply PTFE tape to all threaded parts.
2. For remote installation, an NLGI #1 grease is recommended for best results.
3. For NPT lube points, use thread converter (10).

Note : All parts above are Metric thread.