

DETAILED PARTS AND ASSEMBLY PROCEDURE

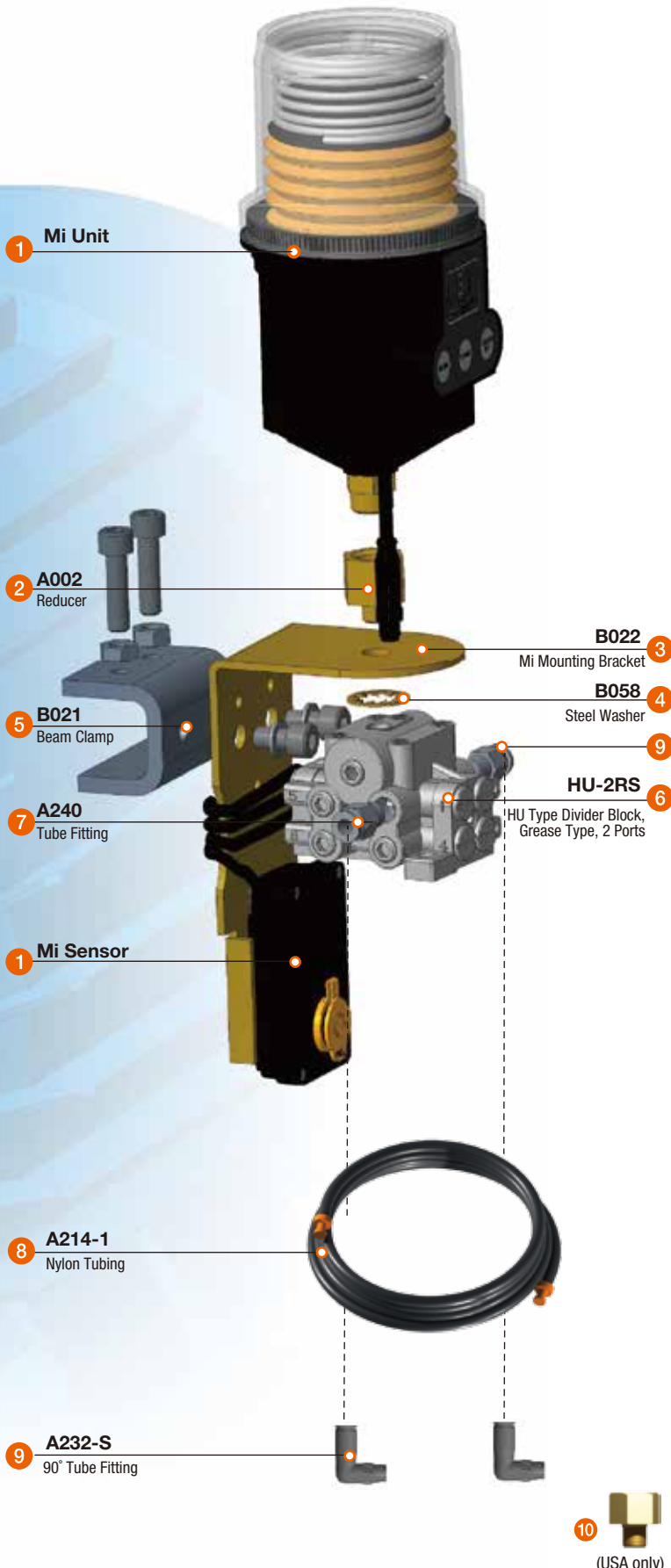

LIST	Part No.	DESCRIPTION	Q'TY
1	Mi Unit	Pulsarlube Mi Series (Includes sensor)	N/A
2	A002	Reducer, 3/8" F X 1/8" M Adaptor (Brass)	1
3	B022	Mi Mounting Bracket	1
4	B058	Steel Washer	1
5	B021	Beam Clamp 30mm (Stainless)	1
6	HU-2RS	HU Type Divider Block, Grease Type, 2 Ports	1
7	A240	Tube Fitting, Push-In Type, PC6-PT1/8" M	2
8	A214-1	Distribution Tubing, O.D. 1/4"(6mm) Nylon Tubing, 10ft (3m) Pre-filled with (Grease Type)	1
9	A232-S	90° Tube Fitting, Push-In Type, PC6-PT1/8" M Swivel Type (Nickel Plated)	2
10	A243	Metric to inch thread converter for bearing zerck (USA only)	1

Assembly Procedure

1. Assemble Mi Mounting Bracket (3) and Beam Clamp (5) together.
2. Install HU-2RS (6) on the Mi Mounting Bracket (3) firmly using provided reducer (2) and washer (4).
3. Install tube fittings (7) into divider block.
4. Place Beam Clamp (5) on the motor and tighten the bolts until the clamp is affixed.
5. Install 90° swivel fittings (9) into lube point.
6. Connect nylon tubing (8) to tube fitting and 90° swivel fitting.
7. Install Mi unit and Mi Sensor (1) as shown.
8. Follow operation and calibration instructions on Mi unit user manual.

Product Comments

1. Mi Sensor checks for ambient vibration every hour.
2. Periodic check-ups are required to ensure proper performance.
3. Service Pack (Grease Pouch and Battery Pack) must be replaced when the dispensing cycle is finished. The Grease Pouch and Battery Pack must be replaced together at the same time.

Comments

1. Apply PTFE tape to all threaded parts.
2. For remote installation, an NLGI #1 grease is recommended for best results.
3. For NPT lube points, use thread converter (10).

Note : All parts above are Metric thread.